

Pre-augering

Pre-augering is carried out in advance of sheet pile installation to loosen the sub soils to enable piles to be driven into ground conditions that might otherwise not be suitable for a sheet pile solution or would require an uneconomically heavy pile section.

The Fussey Piling Telescopic Leader Rigs are fitted with the MB50 auger motors. A nominal 400mm diameter auger is then attached to the auger drive unit, the ground is then augered usually to the full pile depth at 600mm centres located at the position of the pile clutches, as shown in the sketch below.

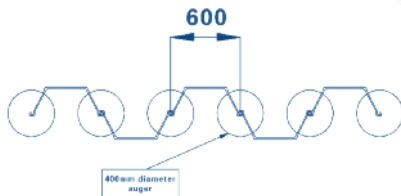

Typically the intention is to loosen the soil rather than create an empty bore. The auger flights are rotated into the ground one direction and counter-rotated to remove them leaving the sheared soil in place in the ground. A small amount of spoil is created to allow for the volume of the auger flights. This spoil needs to be removed from the pile line in advance of the sheet pile installation. Depths of up to 17.0m can be achieved using the MB50 motor.

The effects of pre-augering

- To locally disturb the soil to enable piles to be installed.
- The effect is short lived as soil is reconsolidated when the piles are vibrated or water jetted into the ground
- Can be used in advance of pile pressing techniques to reduce the size of pile required
- Can be used to reduce the need for water jetting
- Can assist in reducing the effects of ground-borne vibrations when used with vibratory techniques
- Can reduce the need for using an impact hammer to final drive piles
- Can help to locate under ground obstructions in advance of pile installation

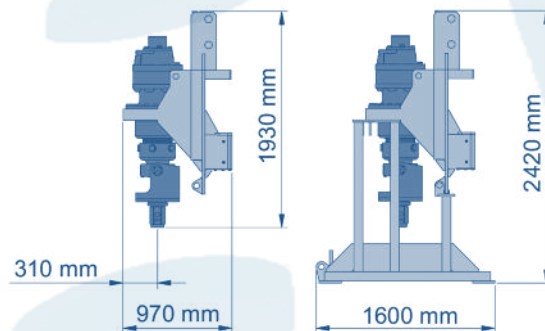

AUGER MOTOR	MB 50
A Height	1880 mm
B Width	710 mm
C Depth	840 mm
Max. torque (300bar)	47.0 kNm
Max. torque (330 bar)	52.6 kNm
Max. pressure	375 bar
Max. speed	80 rpm
Axial load (traction/pressure)	220 kNm
Hexagon socket SW	120 mm



ADVANTAGES

- Enables piles to be installed into difficult soils
- Improves installation rates
- Optimises pile section choice for better economy
- Very short term disturbance to the soils
- Reduced ground borne vibration
- Can help to achieve a limited toe into otherwise impenetrable strata

Water Jetting

Water Jetting is primarily used to enable pile installation with pile pressing techniques into ground conditions that otherwise would be unsuitable due to either dense sands/gravels or stiff clays. A secondary benefit of water jetting is to significantly improve the rate of pile installation and hence reduce costs, as well as optimising the sheet pile section required.

Water jetting is carried out via a high-strength steel jetting lance pipe attached to the inside of the sheet pile 'pan', as shown right.

The jet is operated at low pressures in the initial stages of the installation. The jet is operated continuously throughout the installation to maintain a clear jet nozzle and the pressure adjusted in response to the ground resistance to enable the optimum penetration of the pile to be achieved with a minimum disturbance to the structure of the ground.

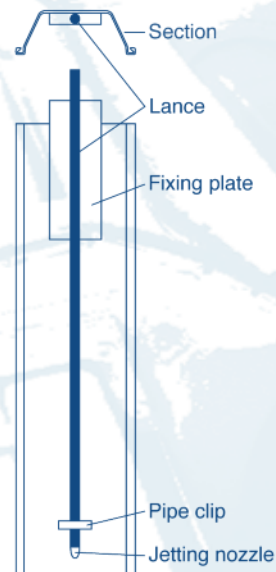

The effects of Water Jetting

When piles of any type are installed into granular soils, most of the resistance to pile penetration results from the creation of a pressure bulb in the soil at pile toe level. Water jetting applied close to the toe of the pile during installation will reduce these effects.

- **In fine to medium granular soils**
To increase local pore water pressure to reduce inter particle friction.
- **In coarse granular soils**
To oscillate granular particles reducing resistance to pile penetration.
- **In cohesive soils (clays)**
Acts as lubrication to reduce adhesion of the piles to the clays, thereby reducing the pressing resistance of the soil.

When jetting in close proximity to sensitive structures there is some possibility of washing out fines, particularly in granular soils, which could lead to settlement. This risk should be addressed prior to adopting this technique with advice from Fussey Piling.



ADVANTAGES

- Enables pile pressing into difficult soils e.g. very stiff clays and granular strata
- Improves installation rates
- Optimises pile section choice for better economy
- Very short term disturbance to the soils
- Can also be used with water jetting